

## Bearing into blockwork cavity wall using Energy Stop

When bearing into cavity wall ensure that the STEICOjoist is cut 10mm shorter than the full bearing length so that the Energy Stop does not protrude into the cavity.

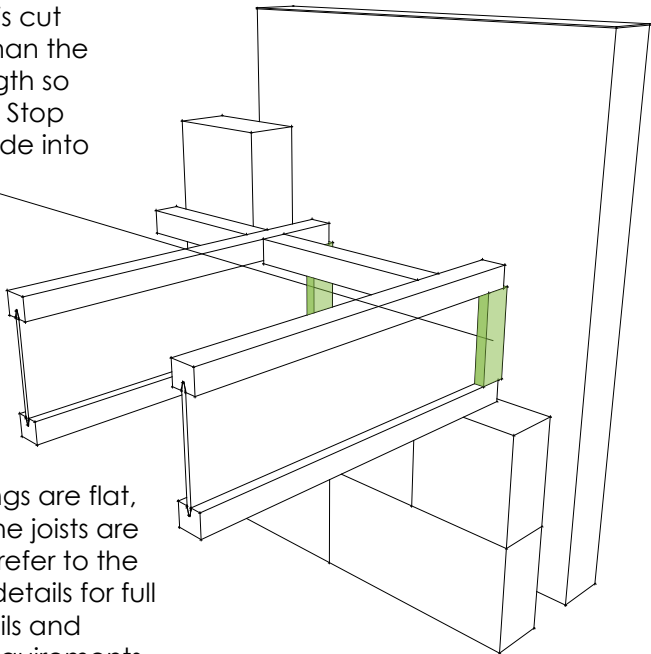

Ensure all bearings are flat, level and that the joists are vertical. Please refer to the manufacturers details for full installation details and restraint strap requirements